

PERFORMANCE OF CAISSON TYPE QUAY WALLS AT KOBE PORT

HIROFUMI INAGAKIⁱ⁾, SUSUMU IAIⁱⁱ⁾, TAKAHIRO SUGANOⁱⁱ⁾,
HIROYUKI YAMAZAKIⁱⁱⁱ⁾ and TAKAMASA INATOMIⁱⁱⁱ⁾

ABSTRACT

Many caisson type quay walls were damaged in Kobe Port during the 1995 Hyogoken-Nambu earthquake. Seaward displacements of the caisson walls were about 5 m maximum and 3 m average. Although the caisson walls also tilted and settled, they did not collapse or overturn and deformed quite uniformly maintaining almost straight face lines of the walls along the port front alignment (pier head).

The high seismic resistant quay walls of a caisson type, which were specifically designed for unloading emergency supplies, performed very well and resisted the strong earthquake motion.

Geotechnical investigations including in-situ soil freezing sampling and shake table tests were performed in order to understand the mechanism of deformation in the caisson walls. The displacements of the caisson obtained from the shake table tests agreed very well with those measured in Kobe Port after the earthquake. The results of these investigations suggested that the excess pore water pressure increase in the foundation soil underneath the caissons and in the backfill soil significantly increased the deformation of the caisson walls.

Key words: case history, earthquake, earthquake damage, earthquake resistant, liquefaction, quay walls, sand, sandy soil, soil-structure interaction (IGC: E8/E12)

INTRODUCTION

Kobe Port is located south of Kobe city about 17 km from the epicenter of the 1995 Hyogoken-Nambu earthquake. At the time of the earthquake, the port had 186 quay walls, about 90 percent of which were caisson type walls. Most of these caisson walls moved toward the sea about 5 m maximum and about 3 m average, and inclined about 4 degrees toward the sea. About the same order of magnitude of settlement was induced in the soil backfill behind the walls. These displacements of the caisson walls were among the largest in the history of the Japanese earthquake experience in port areas.

There were three quay walls which did not suffer serious damage in this port. Two of them were caisson type and one was trestle pier type. These quay walls, called high seismic resistant quay walls, were specifically designed to resist the maximum credible earthquake motion in this area in order to provide a key function for Kobe Port immediately after a major earthquake for unloading medical, food and other emergency supplies to the areas devastated by the earthquake.

These caisson type quay walls in Kobe Port were shaken by a very strong earthquake motion. The peak ground accelerations recorded at Kobe Port were 0.54 g

and 0.45 g in the horizontal and vertical directions and the peak velocities were 122 cm/s and 34 cm/s. In addition, there was extensive evidence of liquefaction of the landfill, which may have a considerable influence on the performance of the quay walls. The possibility of liquefaction of the foundation soils beneath the caisson walls was also suspected. How these factors affected the performance of the caisson type quay walls was one of the most frequently discussed matters since the earthquake.

Based on the contrast between the damaged and undamaged quay walls as well as in-situ geotechnical investigations and shake table tests, this paper presents essential data and discussions to understand how serious damage occurred to many of the caisson type quay walls.

KOBE PORT

Kobe Port covers an area about 6 km long by 12 km wide including a coast line south of Kobe city and two man-made islands further south in the sea as shown in Fig. 1. The origin of modern Kobe Port dates back to the beginning of the 20th century when a major renovation and construction began along the coast line from west to east to complete Hyogo and Shinko Piers and Maya

ⁱ⁾ Former Director General, The Third District Port Construction Bureau, Ministry of Transport, Kobe.

ⁱⁱ⁾ Port and Harbour Research Institute, Ministry of Transport, Nagase 3-1-1, Yokosuka 239.

Manuscript was received for review on August 17, 1995.

Written discussions on this paper should be submitted before August 1, 1996, to the Japanese Geotechnical Society, Sugayama Bldg. 4F, Kanda Awaji-cho 2-23, Chiyoda-ku, Tokyo 101, Japan. Upon request the closing date may be extended one month.

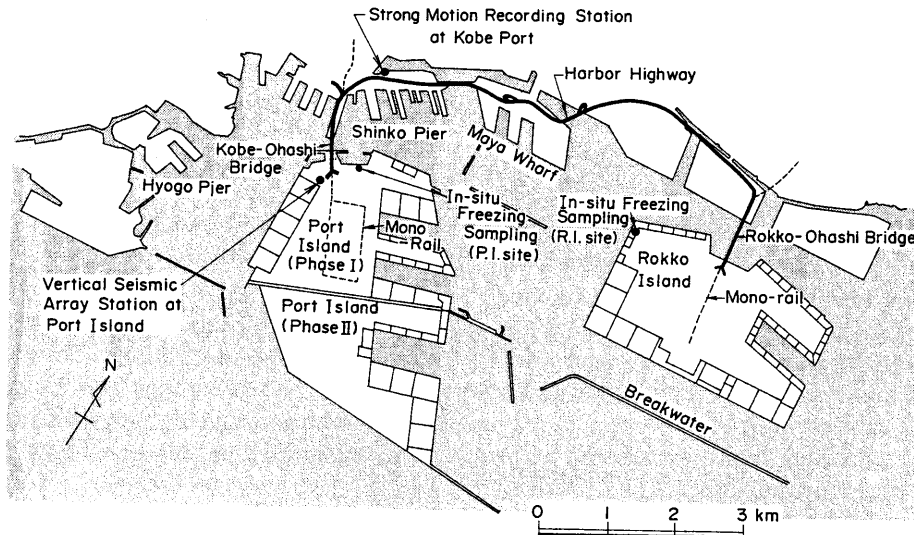

Fig. 1. Plan of Kobe Port, locations of recording station, quay walls and sites for geotechnical investigation

Wharf in 1966. The construction of the two man-made islands, Port Island and Rokko Island, began in 1966 and 1972 respectively, using land reclamation methods. The soils used for landfill were excavated from the Rokko mountains running north west of Kobe city, transported and placed in-situ by bottom dump type barges in the sea with a water depth ranging from 10 to 15 m. The northern half of Port Island, called Phase I, was completed in 1981, followed by the completion of Rokko Island in 1990. The landfilling at the southern half of Port Island,

called Phase II, was almost complete when the earthquake hit Kobe Port in January 1995.

CAISSON TYPE QUAY WALLS

As mentioned earlier, about 90% of the quay walls in Kobe Port were caisson type. Typical cross sections of the caisson type quay walls are shown in Figs. 2 and 3. The caisson type quay walls maintain their stability utilizing the friction at the bottom of the caisson in order to

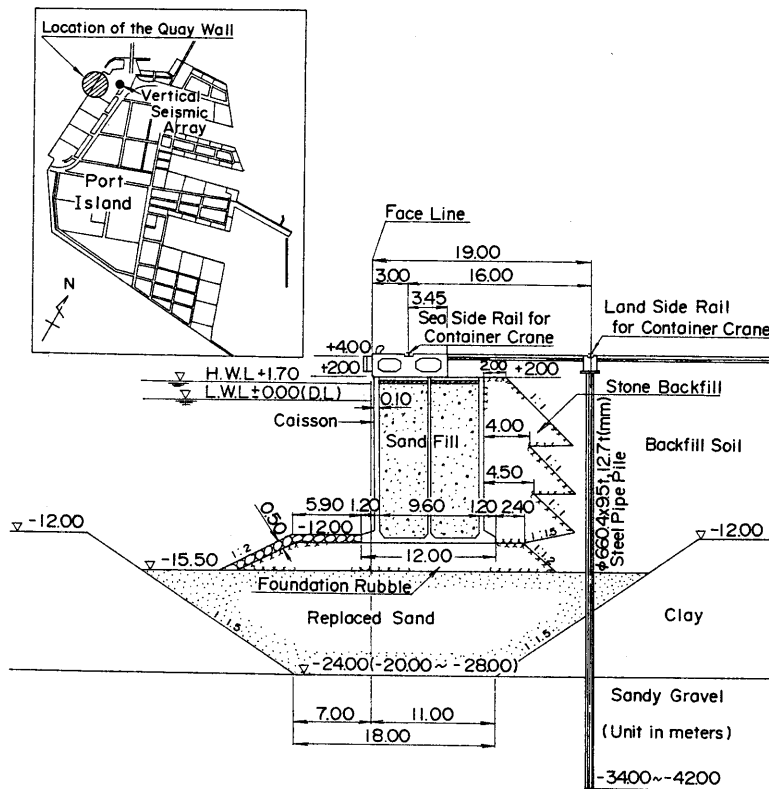

Fig. 2. Cross section of a quay wall at Port Island

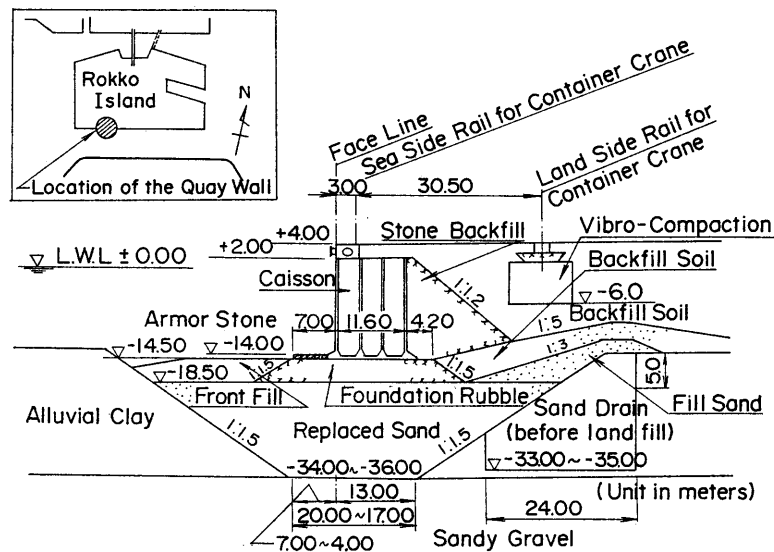

Fig. 3. Cross section of a quay wall at Rokko Island

resist seismic inertia force and hydrodynamic and earth pressures acting on the wall. The caisson type quay walls in Kobe Port were designed using a pseudo static method with seismic coefficients ranging from 0.10 to 0.25 specified as a fraction of gravity. Variation in these coefficients reflects the difference in the site conditions and the level of safety specified by the importance factor in the design code (Ministry of Transport, 1991). The quay walls shown in Figs. 2 and 3 were designed with seismic coefficients 0.10 and 0.15, respectively. A seismic coefficient of 0.25 was used for designing the high seismic resistant quay walls mentioned earlier.

One prerequisite for maintaining the stability of the caisson type quay walls is that the foundation soil beneath the caisson has sufficient bearing capacity. If the foundation soil is, for example, soft alluvial clay as in Kobe Port, the foundation soil should be improved to meet the required bearing capacity.

Among the various soil improvement techniques, the sand replacement technique was most commonly used for the foundation soil in Kobe Port. The soils used for the replacement in Kobe Port were obtained from the same mountains as those used for landfill mentioned earlier. The soils used for landfilling in Port Island (Phase I) and a part of Rokko Island were decomposed granite called Masado and those used in a major part of Rokko Island and Port Island (Phase II) were decomposed tuff and mudstone. The grain size distribution curves of the Masado are shown in Fig. 4. The zones shown in the same figure are those for identifying liquefiable soils from well graded soils as inferred from past earthquake experience in port areas in Japan (Tsuchida, 1970). As shown in this figure, the Masado contains large grain size particles as well as fine grained particles. The gradation curves shown in Fig. 4 are the portion of Masado which passed 20 mm mesh sieve whereas the Masado in the field contains particles as large as 50 mm or larger. There was extensive evidence of liquefaction of the Masa-

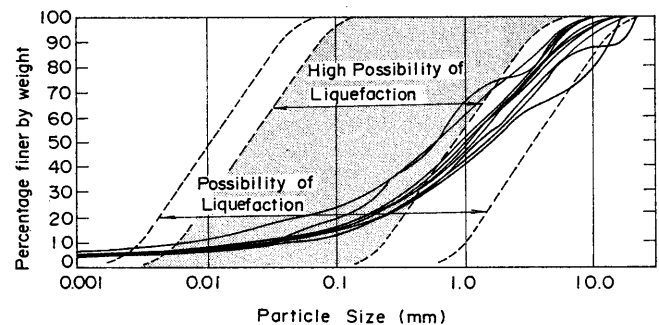

Fig. 4. Grain size accumulation curves of Masado (i.e. decomposed granite) used for landfill

do used for landfill in the Port Island (Phase I) and other landfills as reported elsewhere in this special issue of Soils and Foundations.

The sand replacement underneath the caisson was undertaken to a depth which allowed complete removal of the clay layer. The depth of the lower boundary of the clay layer in Kobe Port ranges from about 10 m to 45 m, gradually deepening from the north west toward the south east.

IN-SITU FREEZING SAMPLING AND OTHER GEOTECHNICAL INVESTIGATIONS

Foundation soils beneath the caisson walls and backfill soils behind the walls play a crucial role in the performance of the caisson type quay walls. In order to evaluate the mechanical properties of those soils under seismic loading, various geotechnical investigations were completed including velocity logging, in-situ freezing sampling and cyclic triaxial tests.

The in-situ freezing sampling was conducted at two sites. One was at the northern end of Port Island and the other at the north east corner of Rokko Island as

shown in Fig. 1. Since the results of the geotechnical investigations at these two sites were similar to each other, only the one at Rokko Island will be described in detail. The cross section of the sampling site, the SPT *N*-values and the gradation curves of the soils are shown in Fig. 5. Since the landfill soils contained large particles of the order of 5 cm or larger as mentioned earlier, it was decided to use a triple tube sampler 30 cm in diameter to obtain samples by coring the frozen soil body in the soil mass. Two frozen samples were obtained as a long cylindrical solid body from a depth ranging from 4 m to 26 m below the ground surface. Two specimens at depths shown in Fig. 5, one from the backfill soil and the other from the sand replacement, were trimmed from the frozen solid body for cyclic triaxial tests using a large apparatus for testing samples 30 cm in diameter and 60 cm high.

Before cyclic loading, the specimens were consolidated under isotropic confining pressures equal to the in-situ vertical effective stresses. The results of the cyclic triaxial tests are shown by solid marks in Fig. 6 in terms of the

cyclic stress ratio versus the number of load cycles required to cause 1, 2, 5 and 10% axial strain in double amplitude. The cyclic stress ratio is defined as the ratio of cyclic deviator stress $\tau_d = (\sigma_1 - \sigma_3)/2$ to initial confining pressure σ'_c .

In order to summarize the results of tests on the frozen samples both from Port and Rokko Islands, the cyclic stress ratios causing 5% strain in double amplitude at 15 load cycles were plotted in Fig. 7 related to the SPT *N*-values. Following Seed et al. (1985), the SPT *N*-values were normalized with respect to a confining pressure of 98 kPa. Energy corrections were also made with respect to the rod energy ratio of 78 percent, which represents the average rod energy ratio of the free fall method used in Japanese SPT practice. Parallel coordinates specified by the equivalent *N*-values and the equivalent accelerations are those widely used in ports and coastal areas in Japan (Iai et al., 1989; Ministry of Transport, 1991).

Also shown in this same figure are the field correlations between SPT *N*-values and cyclic stress ratios obtained by Seed et al. (1985), Yoshimi (1993), and the second

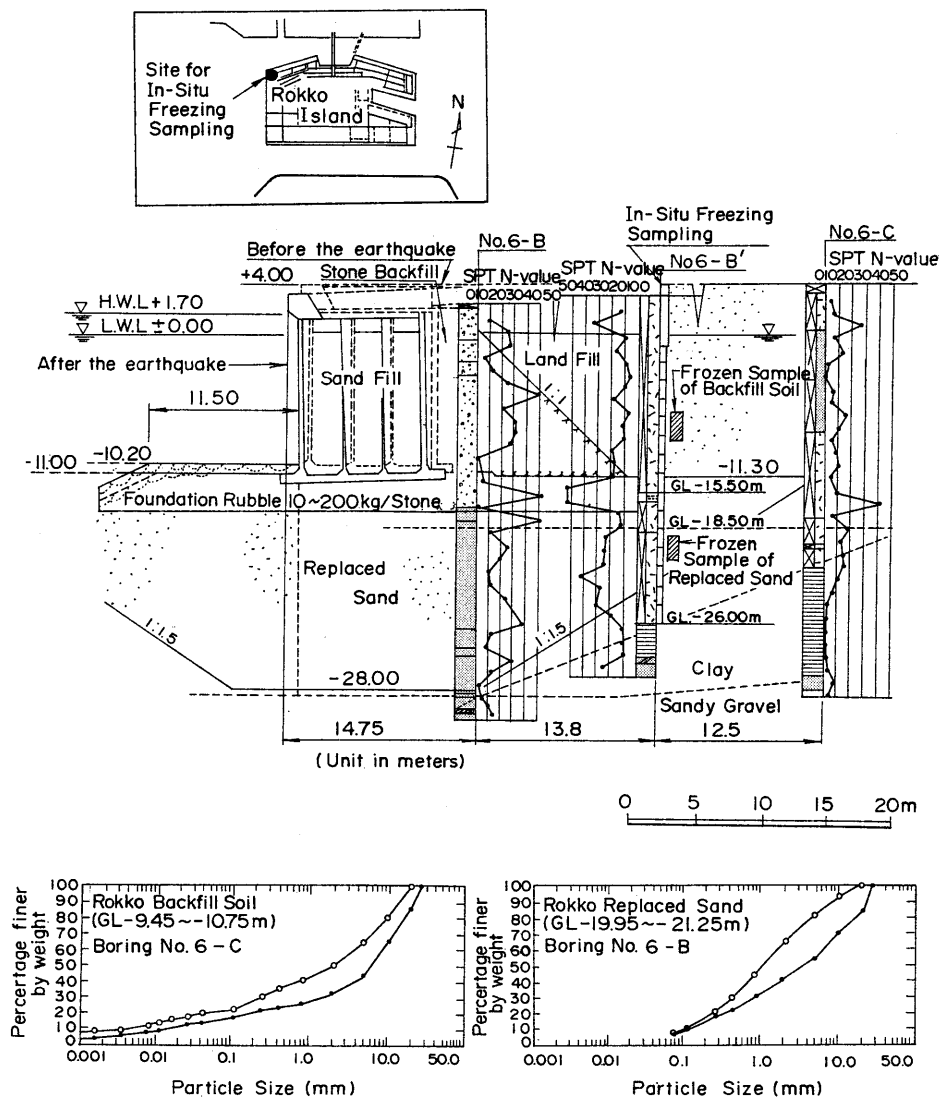

Fig. 5. Cross section of the site for in-situ freezing sampling at Rokko Island

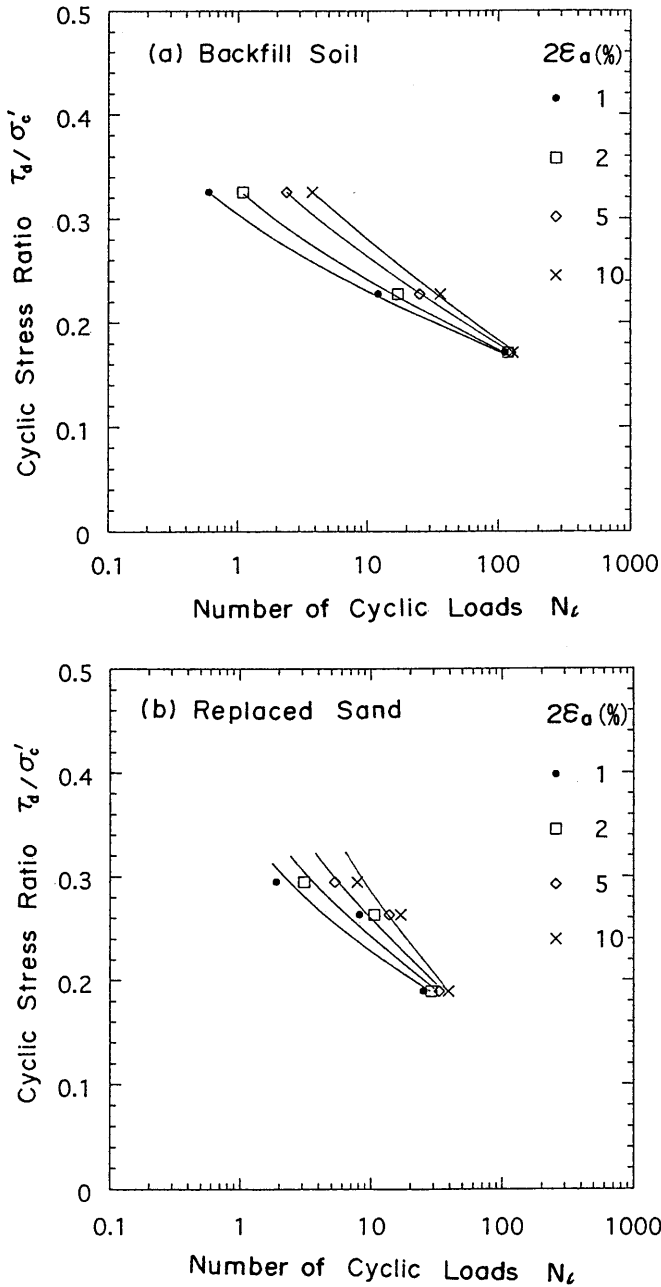

Fig. 6. Cyclic triaxial test results of the samples from Rokko Island

author and his colleagues (Iai et al., 1989), the last of which was adopted in the current design code for port and harbour areas in Japan (Ministry of Transport, 1991). The γ_l shown in the figure for the correlation by Seed et al. (1985) indicates a single amplitude of shear strain at 15 load cycles for clean sands. The curve by Yoshimi (1993) is given for a 5% double amplitude of axial strain for clean sands. The correlation by Iai et al. (1989) indicates a boundary between liquefiable and non-liquefiable conditions for the sands whose gradation curves are within the zone of high possibility of liquefaction shown in Fig. 4. This boundary also corresponds to that in the design code between the zone II (high liquefaction potential) and the zone III (low liquefaction potential) (Ministry of Transport, 1991).

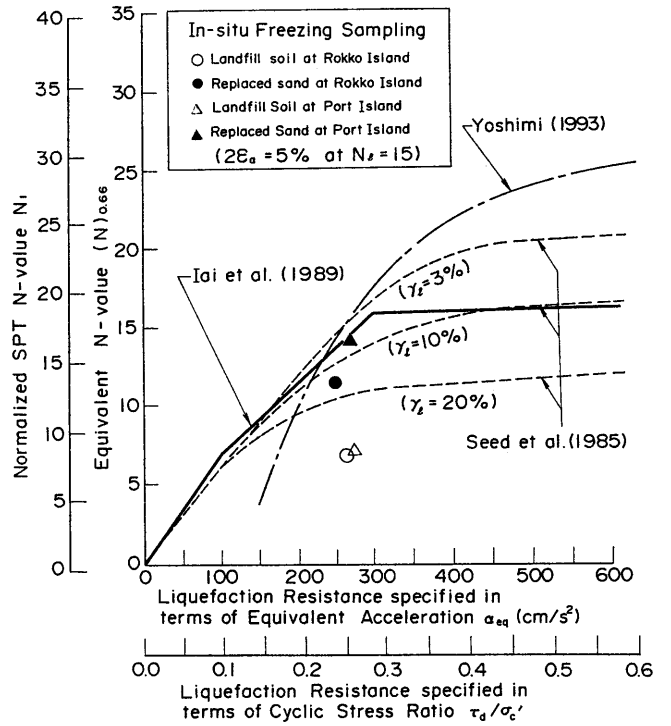

Fig. 7. Comparison of cyclic triaxial test results of the frozen samples of sand replacements and backfill soils obtained at Port and Rokko Islands with the field correlations by Seed et al. (1985), Iai et al. (1989) and Yoshimi (1993)

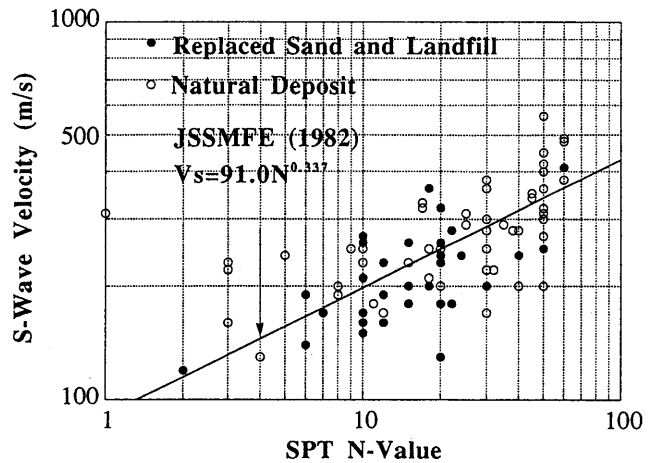
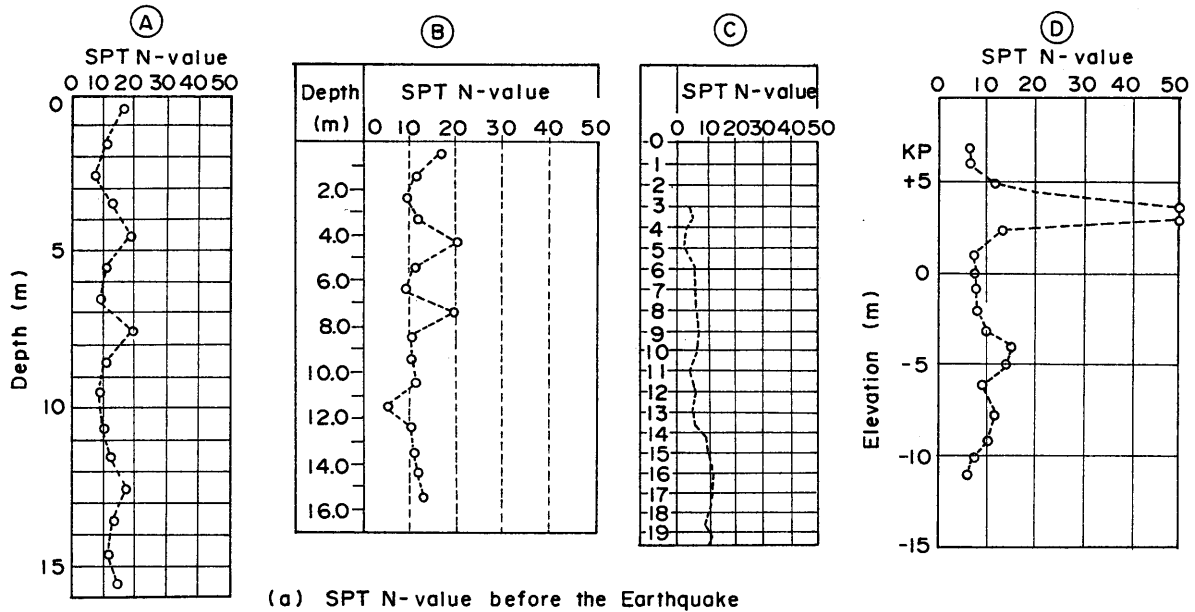

Fig. 8. Relation between shear wave velocity and SPT N -value at Port and Rokko Islands

Figure 7 indicates that these field correlations are basically consistent with the data for the sand replacement at both Port and Rokko Islands. The data for the landfill soil at both Port and Rokko Islands are higher in the cyclic stress ratio relative to the normalized SPT N -value. This can be explained by the fact that the landfill soils in Kobe Port contained more fine grained materials than the sand replacements.

Velocity logging and standard penetration testing were performed at 12 sites in and around Port and Rokko Islands. The results are summarized in Fig. 8. A relation-



(a) SPT N-value before the Earthquake

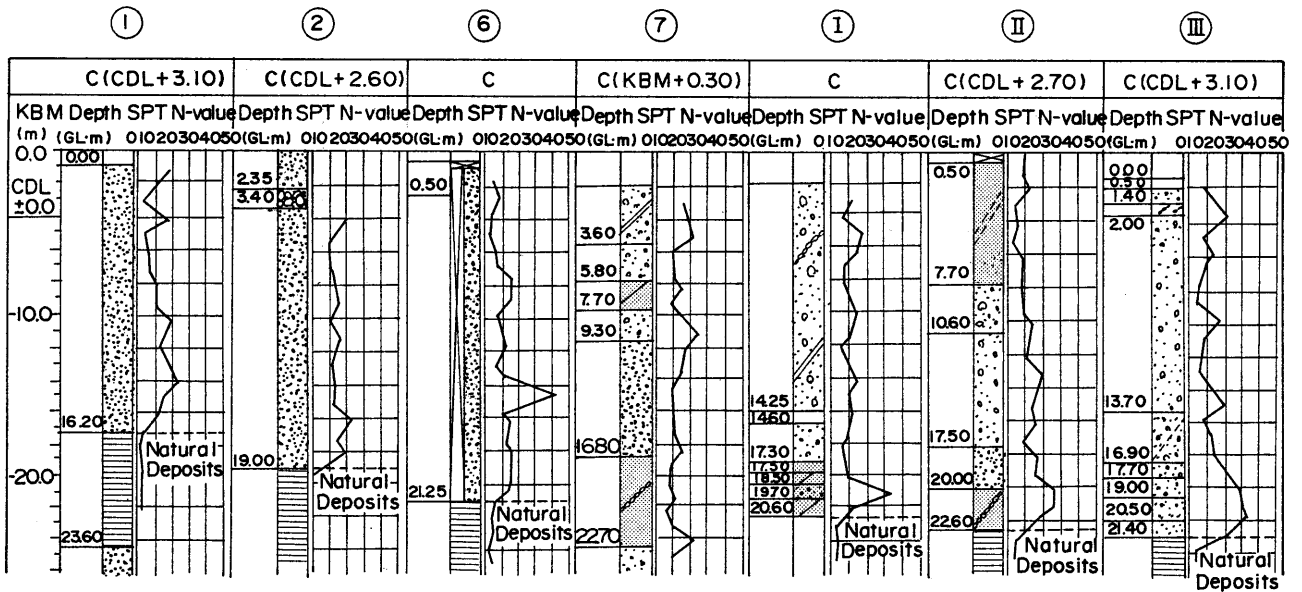
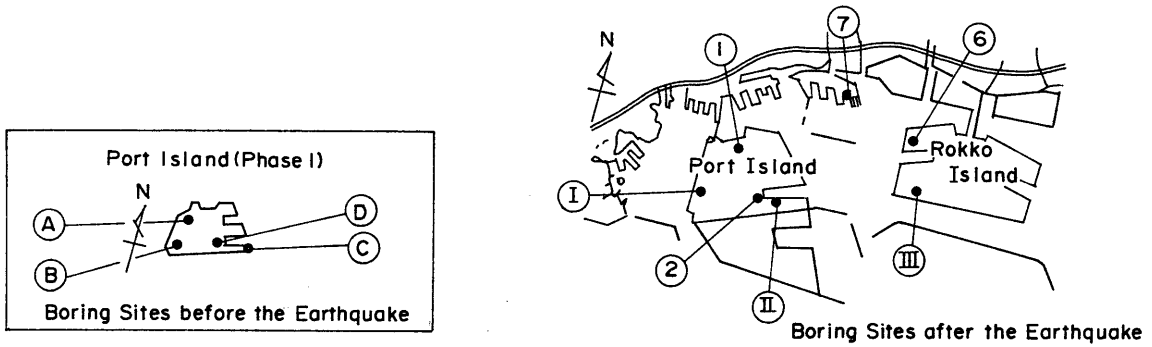

(b) SPT N-value after the Earthquake

Fig. 9. SPT N-values of landfill before and after the earthquake

ship inferred from the past investigations in Japan (Japanese Society of Soil Mechanics and Foundation Engineering, 1982) is also shown in this figure. Although this relationship is based on commonly encountered soils in Japan which are different from those soils used for landfill in Kobe, it compares well with the landfill soils in Kobe.

Since these soil investigations were done after the earthquake, there was a possibility that these soil properties were different from those before the earthquake. The SPT *N*-values of landfill before and after the earthquake are shown in Fig. 9. Some of the SPT data before the earthquake were obtained by Fudo Construction Co. (1995). These results show that the SPT *N*-values of landfill before and after the earthquake range from about 5 to 10 and there is not a large difference between the SPT *N*-values of landfill before and after the earthquake. Since the SPT *N*-values are good indices of many of the soil properties relevant to earthquake response and liquefaction studies, the results obtained by the geotechnical investigations after the earthquake are considered good approximations of those before the earthquake.

EARTHQUAKE MOTIONS AT KOBE PORT

At the time of the January 1995 earthquake, many earthquake motion records were obtained in the Hanshin area as reported elsewhere in this special issue. In Kobe Port, the authors recorded the earthquake motion at the ground surface at the recording station shown in Fig. 1. The record was obtained by a SMAC-B2 accelerograph and was digitized and corrected for the instrument response. The corrected time histories of the accelerations are shown in Fig. 10.

The site condition at the recording station is indicated

by a boring log shown in Fig. 11, which was obtained by a site investigation conducted about two weeks after the earthquake. The ground water level was not measured

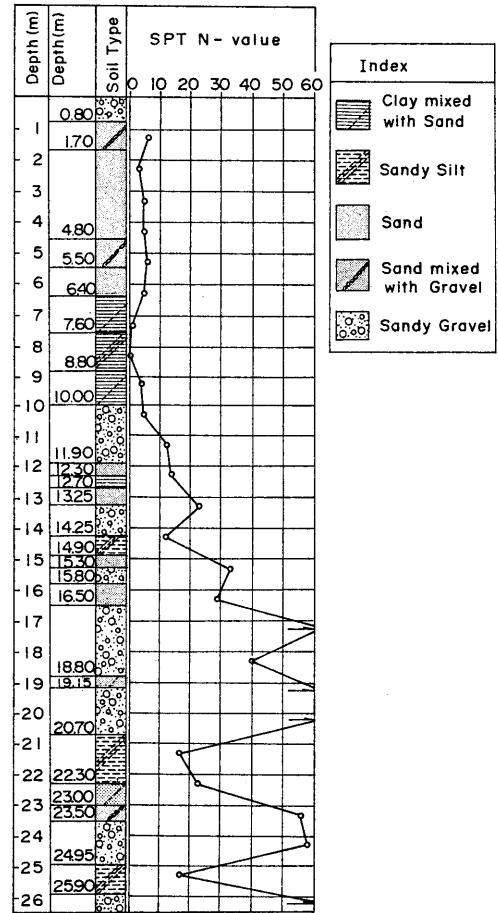

Fig. 11. Boring log of the earthquake recording station at Kobe Port

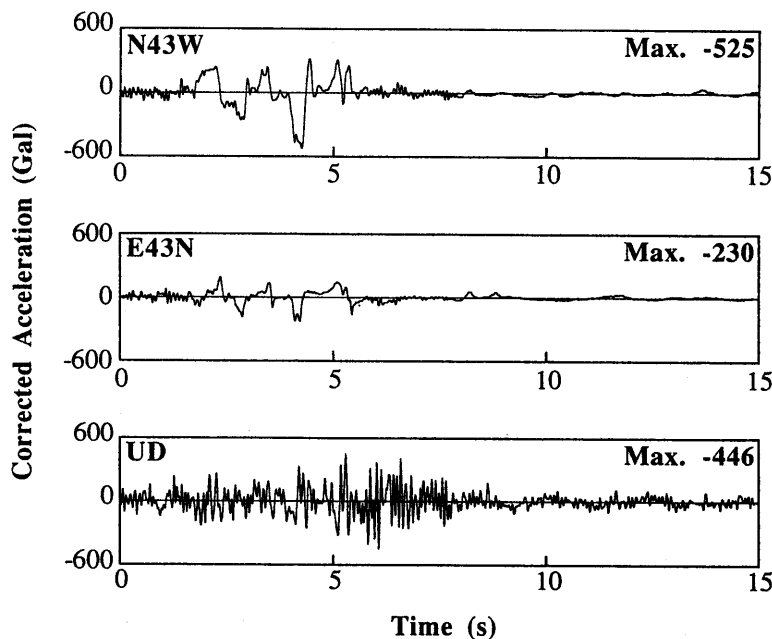

Fig. 10. Acceleration time history of the earthquake motions at Kobe Port

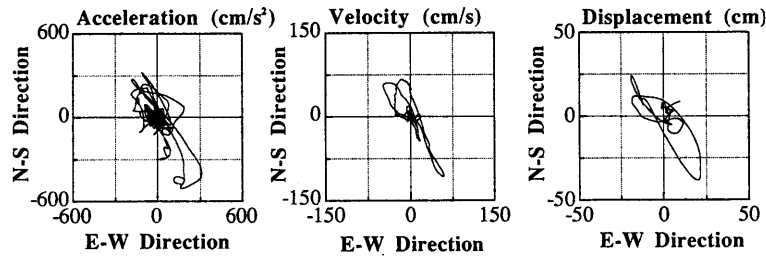

Fig. 12. Loci of the earthquake motion at Kobe Port

when this boring was done but the boring made in the beginning of July, 1995 indicates that the ground water level is at a depth ranging from 1.3 to 1.4 from the ground surface. As shown in this figure, the subsurface layer down to a depth of 6 m consists of loose sand deposit with SPT N -value of 5, underlain by a clay layer with a thickness of 3 m with SPT N -value of about 3. Below these layers a sandy gravel layer with a thickness of about 6 m is encountered with increasing SPT N -values about 20 on average and alternating layers of dense sandy gravel and clay, each with a thickness of a few meters. Since there was evidence of liquefaction around the recording station, the record is considered affected by liquefaction. The peak ground accelerations at the recording station, however, were very high; 525 cm/s^2 (N43W), 230 cm/s^2 (E43N), and 446 cm/s^2 (UD). The wave forms of the acceleration time histories in Fig. 10 suggest that complete liquefaction occurred after 3 or 4 seconds of strong shaking.

Loci of the earthquake motion, shown in Fig. 12, indicate that the direction of the predominant motion is north west to south east, perpendicular to the direction of the earthquake fault reported elsewhere in this special issue. From the loci of the acceleration, the direction components perpendicular to the face lines of the quay walls were obtained and are shown in Fig. 13. The peak accelerations shown in this figure are those projected along the direction vectors. These direction components of the earthquake motions are one of the most relevant

quantities acting as an inertia force to affect the seismic performance of the quay walls. The acceleration components parallel to the face lines of the quay walls also affect the performance of the quay walls but their influence is indirect, mostly through a change in the behavior of the soils beneath and behind the caisson walls including excess pore water pressure increase in these soils.

Another important set of earthquake motions was recorded with a vertical seismic array in the Port Island at the ground surface and at depths of 16 m, 32 m and 82 m. The recording was successfully executed by the Development Bureau of Kobe City. The records will be used later as the input earthquake motion in the shake table tests on the seismic performance of the caisson type quay walls. Since full descriptions on these records will be given elsewhere in this special issue, its presentation will be omitted here.

DAMAGE TO CAISSON TYPE QUAY WALLS

When the level of earthquake motion exceeds the limiting condition considered in the seismic design of a caisson type quay wall, the caisson wall will move toward the sea, causing settlement in the soil behind the wall. The level of shaking during the 1995 Hyogoken-Nambu earthquake as indicated by the peak ground acceleration of 0.54 g in horizontal direction obviously exceeded the limiting condition considered in the seismic design of a caisson wall designed with seismic coefficients of 0.10 and 0.15.

Typical examples of the damage to the caisson type quay walls designed with the seismic coefficients of 0.10 and 0.15 are shown in Figs. 14 and 15, respectively. The details in the cross sections of these walls are shown in Figs. 2 and 3. The caisson wall shown in Fig. 2 displaced toward sea about 3 m, settled about 1 m, and tilted about 3 degrees average. The wall shown in Fig. 3 displaced toward sea about 4 to 5 m, settled about 2 m, and tilted about 4 to 5 degrees average. The backfill soils behind the walls subsided accordingly in the same order of magnitude as those in the horizontal wall movement. As mentioned earlier, there was no collapse or overturning of the caisson walls throughout Kobe and other ports resulting from the 1995 Hyogoken-Nambu earthquake.

In order to obtain a comprehensive picture of the displacements of the caisson type quay walls, those meas-

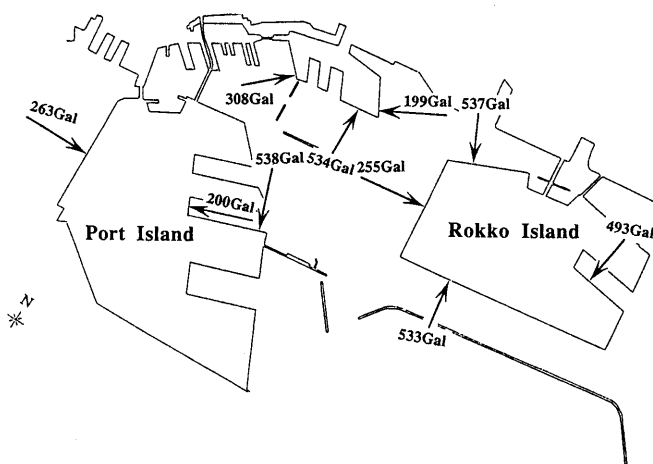

Fig. 13. Direction components of the projected accelerations

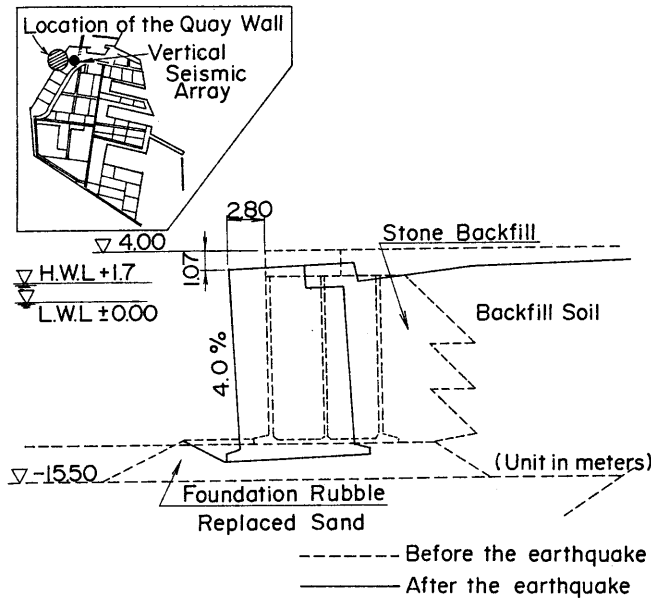

Fig. 14. Deformation of quay wall at Port Island

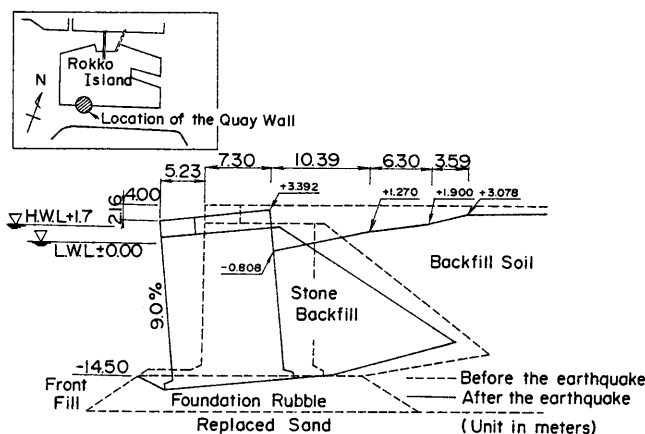

Fig. 15. Deformation of quay wall at Rokko Island

ured and calibrated by the Global Positioning System using a satellite position are shown in Figs. 16 and 17. These measurements were made at the top seaside corner of the caisson walls, thus including the effects of inclination of the walls. These results indicate that predominant displacements tend to occur in north-south direction. This is consistent with the directional components of the accelerations shown in Fig. 13.

Another important feature of the displacements shown in Figs. 16 and 17 is that the deformation of the caisson walls occurred quite uniformly maintaining almost straight face lines of the walls. Since uniform deformation was also manifested in the settlements in the inner part of Port Island as reported elsewhere in this special issue, uniform deformation is considered to reflect the uniformity of the landfill process and/or the intrinsic properties of the material used for landfill such as Masado. The uniform deformation of the quay walls can be considered one of the good aspects of the seismic perfor-

mance of the caisson type quay walls, permitting a provisional use of the displaced quay walls immediately after the earthquake and later contributing to fast and efficient restoration. A detailed study might be necessary to determine completely what factors contributed to these uniform deformations.

UNDAMAGED CAISSON TYPE QUAY WALLS

As mentioned earlier, the high seismic resistant quay walls, located at the western part of the Maya Wharf shown in Fig. 1, did not suffer serious damage. A typical cross section of these quay walls is shown in Fig. 18. As mentioned earlier, these quay walls were designed with a seismic coefficient of 0.25. Larger width to height ratio of the caisson shown in Fig. 18 than those shown in Figs. 2 and 3 was the result of a design using the large seismic coefficient.

There was virtually no damage to the caisson type quay wall except for some settlement of the stone backfill behind the caisson and small displacements of the caisson toward sea of the order of tens of centimeters. The caisson which was designed with the high seismic coefficient obviously performed quite well to resist the strong earthquake motion.

In addition to the large width to height ratio of the caisson wall, the following factors are considered to have contributed to the performance of this wall; 1) the foundation rubble beneath the caisson was directly placed on a sandy gravel layer as shown in Fig. 18, 2) there was an old cellular type quay wall buried behind the current caisson wall, 3) the old cellular type quay wall was placed on a thin sand replacement foundation, and 4) the quay wall was not directed toward the direction of the predominant earthquake motion as indicated by the smaller acceleration component in Fig. 13.

Detailed analysis is now under way on the performance of these walls.

DEFORMATION OF QUAY WALLS AND FOUNDATION SOIL CONDITIONS

The foregoing observation on the performance of the quay walls suggests that, in addition to the effect of the strong shaking such as inertia force, hydrodynamic and seismic earth pressures, the foundation conditions underneath the caisson walls may have significantly affected the seismic performance of those walls.

An interesting example was obtained to evaluate this issue. There were three quay walls constructed along a single straight face line at Port Island (Phase II). One was constructed on sand replacement foundation and two were constructed on a clay foundation which was improved with sand compaction piles (SCP). The locations and the cross sections of those quay walls are shown in Figs. 19 and 20. The seismic coefficients used for the design of these quay walls were 0.18 for PC-13 shown in Fig. 19 and 0.15 for PC-14 and -15 shown in Fig. 20. All of these quay walls were under construction but almost

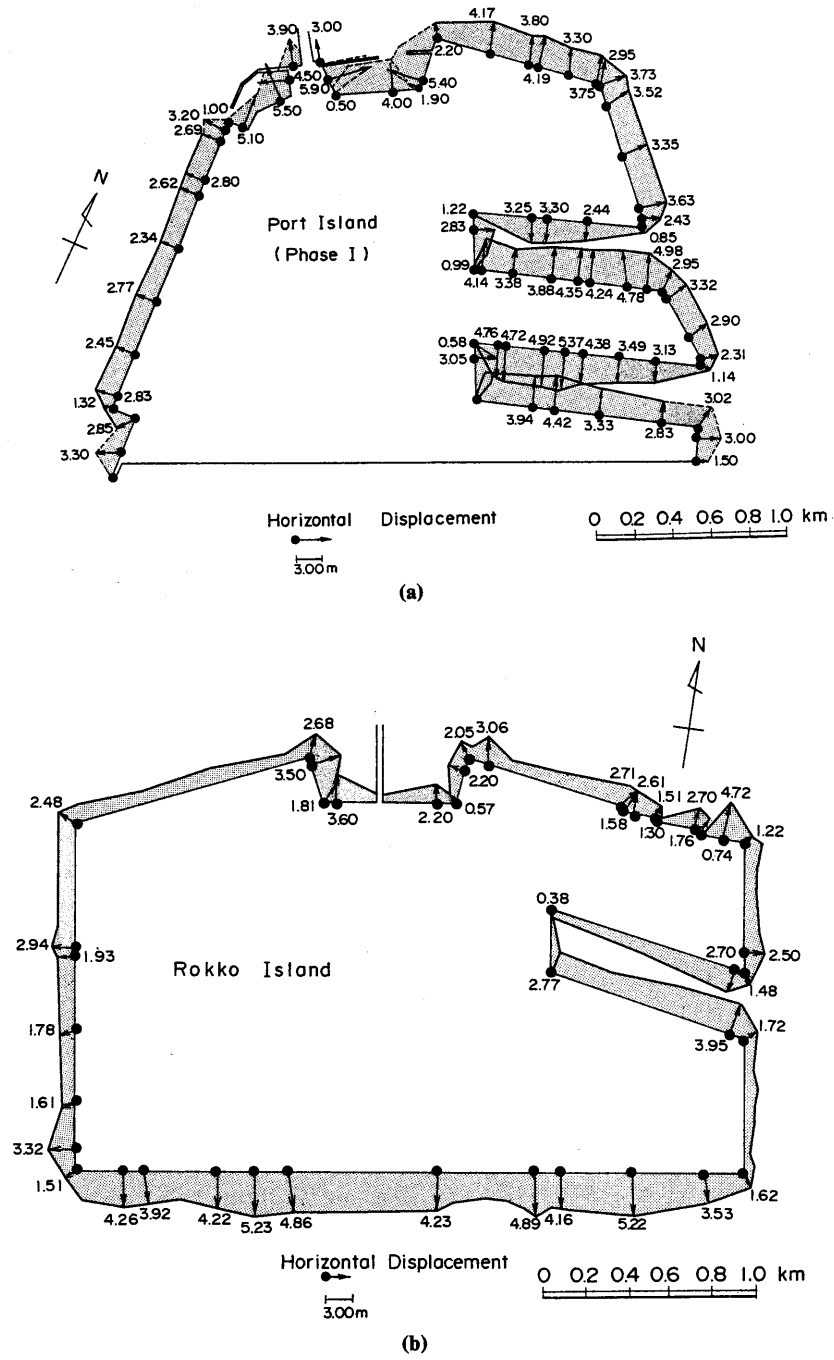

Fig. 16. Horizontal displacements after the earthquake
 (a) Port Island
 (b) Rokko Island

complete at the time of the earthquake.

The horizontal displacements and elevations of these quay walls after the earthquake are shown in Fig. 21. In this figure, the elevations of the caisson walls which were not complete at the time of the earthquake were corrected for those to be finished at the end of the construction. As shown in the figure, the displacements of the quay walls PC-14 and -15 constructed on sand compaction pile foundations were about 2.5 m and 0.3 m in horizontal and vertical directions. These displacements are consi-

dered to have been induced mainly by inertia force, hydrodynamic pressures and earth pressures from back-fill soils. The displacements of the quay wall PC-13 on sand replacement foundation were about 3.5 m and 1.5 m in horizontal and vertical directions. These displacements are much larger than those of PC-14 and -15, suggesting the additional effects of the foundation condition.

In order to obtain a comprehensive evaluation of the effect of the foundation conditions, deformation of the

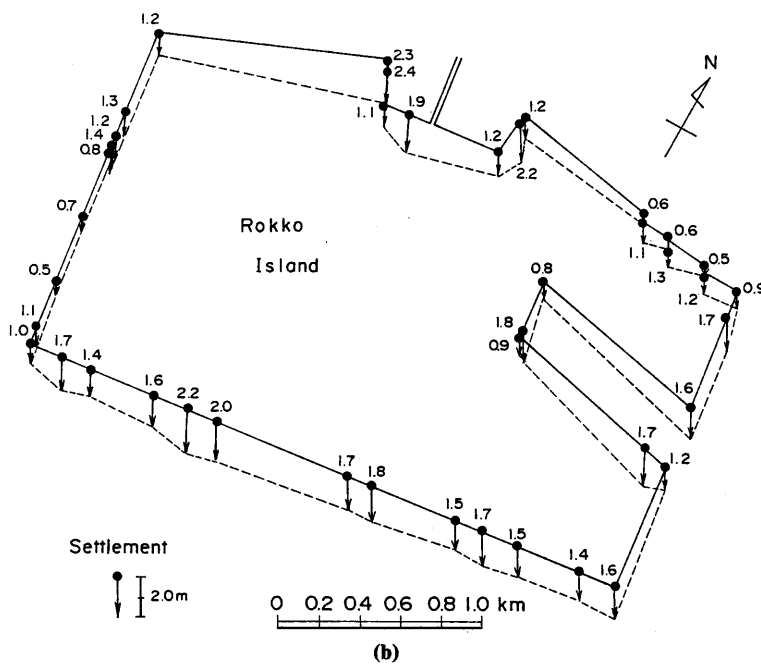
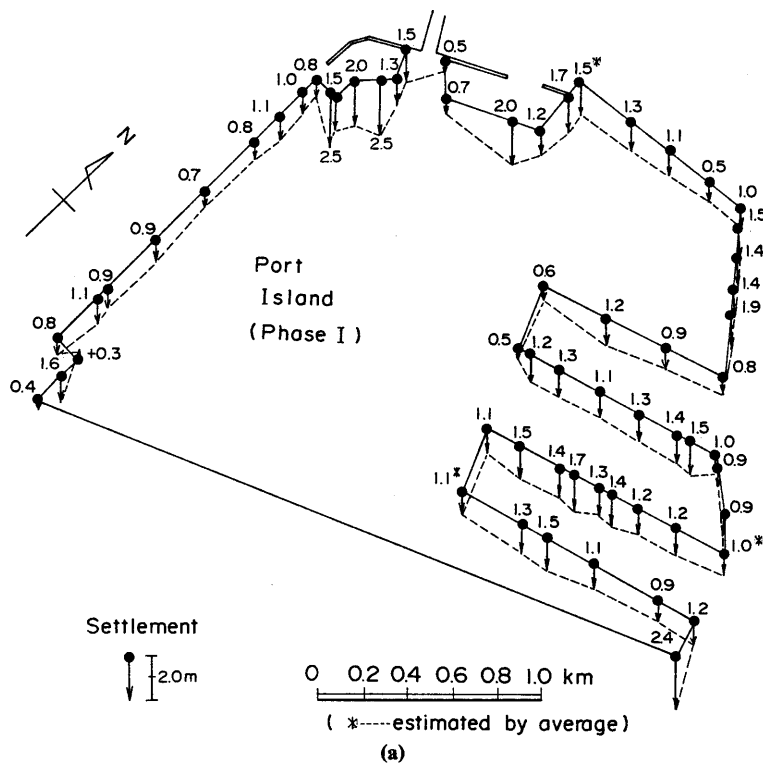

Fig. 17. Vertical displacements after the earthquake
 (a) Port Island
 (b) Rokko Island

quay walls at Rokko Island are plotted as related to the thickness of the sand replacement beneath the caisson walls. The results are shown in Fig. 22. In Fig. 22(d), the horizontal displacement is normalized with respect to the height of the caisson wall. The data shown in this figure include those with various quay wall directions, various heights of caisson walls ranging from 11.5 m to 19.0 m

and variation in the cross sections of the caissons designed with two seismic coefficients 0.15 and 0.18. Despite these variations in the conditions of the quay walls, the settlements and the normalized horizontal displacements shown in Figs. 22(b) and (d) indicate that the thickness of the soil replaced underneath the caisson considerably affected the deformation of the caisson walls.

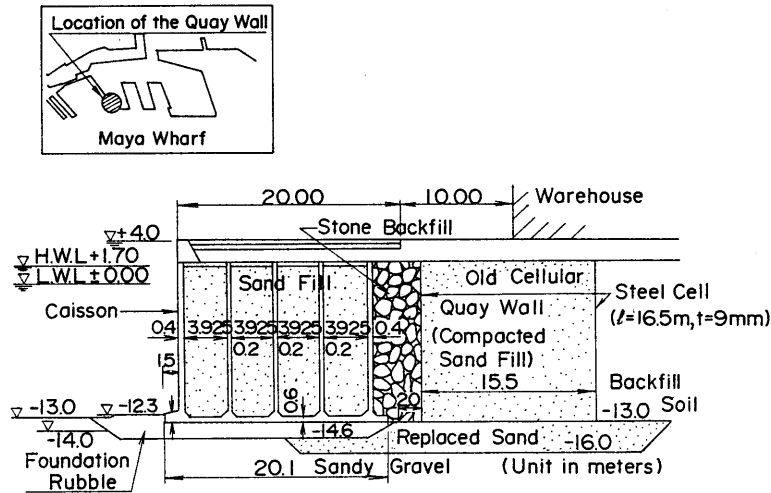

Fig. 18. Cross section of the high seismic resistant quay wall

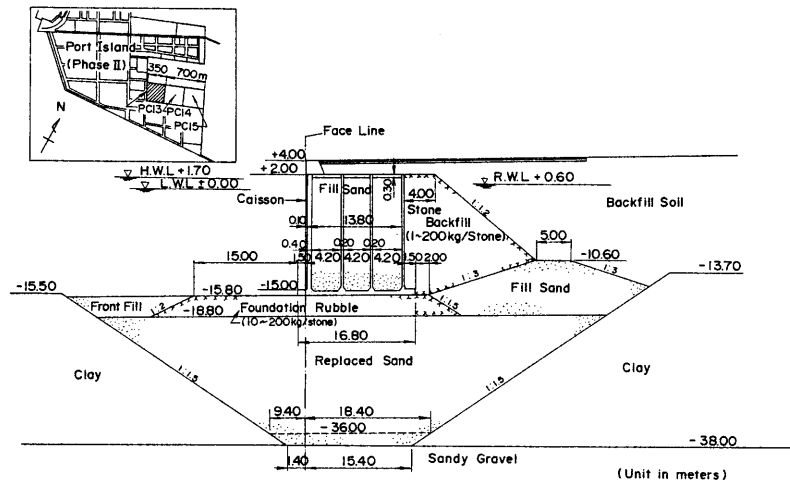

Fig. 19. Cross section of a quay wall founded on sand replacement

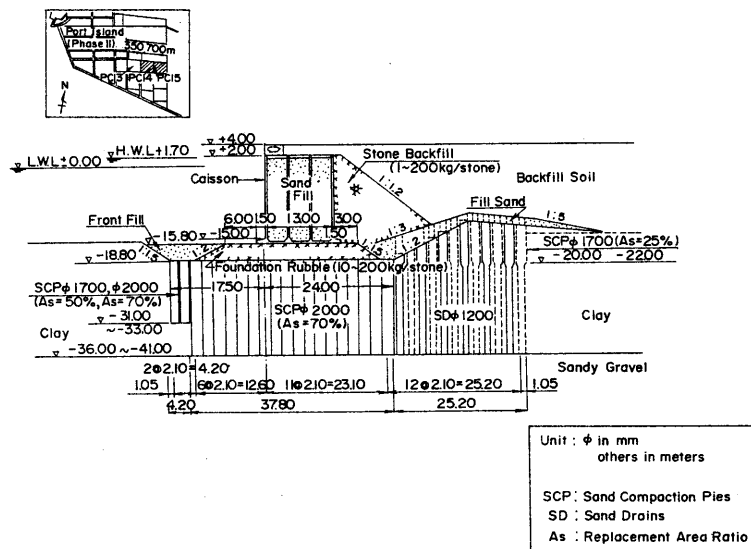

Fig. 20. Cross section of a quay wall founded on subsoil improved with sand compaction piles (SCP)

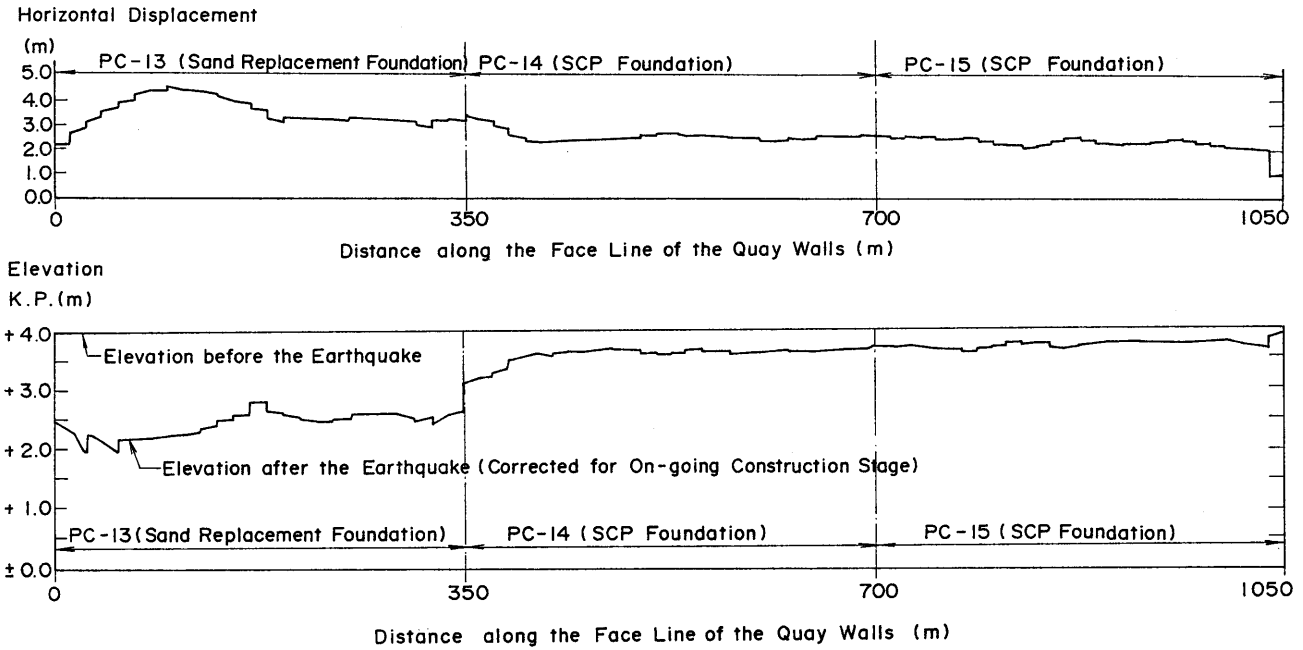

Fig. 21. Displacements of quay walls founded on sand replacement and sand compaction piles (SCP)

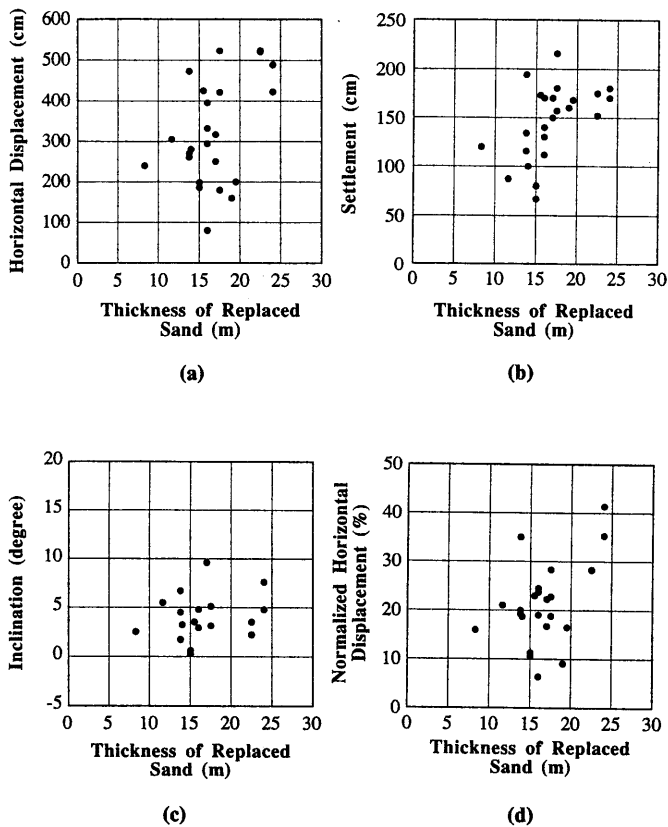

Fig. 22. Statistics of deformation of quay walls correlated with a depth of soil replaced underneath the caisson
 (a) Horizontal displacement
 (b) Vertical displacement
 (c) Inclination
 (d) Horizontal displacement normalized by the height of caisson

DEFORMATION OF FOUNDATION RUBBLE MOUND

In order to obtain physical evidence of the effect of the foundation soils on the performance of the caisson type quay walls, deformation of foundation rubble mound was investigated by diving underwater in front of the caisson walls. The position of the caisson wall relative to that of the foundation rubble mound may offer a key to whether the deformation of the quay walls was induced by sliding of the caisson wall or overall deformation of the foundation soils. The investigation was done in the beginning of April, 1995.

An example of the deformation measured of the rubble foundation is shown in Fig. 23 for the quay wall located at the north west corner of Rokko Island. As shown in this figure, the caisson wall tilted into the foundation rubble and pushed the rubble out in accordance with the displacements of the caisson wall. This seems to support the assumption that the deformation of the quay wall was mainly induced by an overall deformation of the foundation soils.

It can also be considered, however, that the deformation occurred only in the foundation rubble as a local failure. Therefore, it cannot be easily concluded that the overall deformation of the foundation soils was the main cause of the damage to the quay wall.

The investigation by diving also revealed that silty clay covered a part of the foundation rubble mound as shown in Fig. 23. It was reported that the silty clay was different from the soils used as sand replacement beneath the foundation rubble and considered as drifting of seabed mud. There was no confirmed report on the evidence of li-

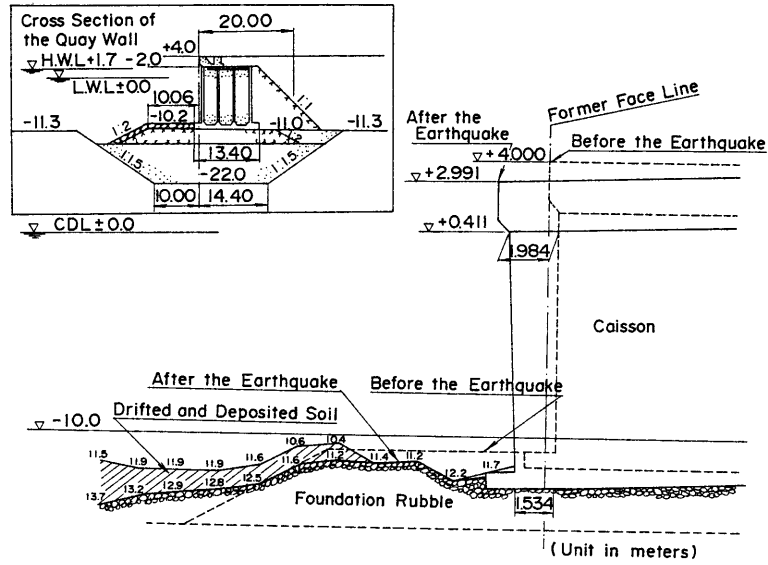

Fig. 23. Deformation of rubble mound beneath the caisson

quefaction on the sea bed in the vicinity of the quay walls in Kobe Port. Therefore, these results did not support the speculation that liquefaction occurred in the sand replacement.

To summarize the results of the in-situ measurements and site investigations presented so far in this paper, these results are rather controversial and inconclusive but at least indicate that seismic inertia force, liquefaction of backfill soil and deformation of foundation soils beneath the caisson affected the performance of the caisson type quay walls. A clear picture has not yet been obtained as to exactly what happened during the earthquake. There was no recording of time histories of displacements of the caisson walls nor excess pore water pressures in the sand replacement beneath the caisson. It is not possible to determine whether the quay wall moved at the time of the maximum accelerations or later mainly due to the effect of the excess pore water pressure increase in the backfill soil. It is either not possible to determine how

high the excess pore water pressure became in the sand replacement.

Many speculations have been made on these matters since the earthquake but the in-situ data has been too limited to solve the controversy. In order to obtain a more comprehensive picture on the performance of the caisson type quay walls, shake table tests were performed to simulate the response of the caisson walls during the earthquake.

SHAKE TABLE TESTS

In the shake table tests, the caisson type quay wall shown in Fig. 2 was modeled at a scale of 1/17 of the prototype. The quay wall model was made in a steel container 3.5 m long by 1.5 m wide and 1.5 m deep on a shake table, which was set in the middle of a water pool 2 m deep and 15 m by 15 m wide to simulate the effect of sea water. The Masado obtained from a site nearby the quay wall

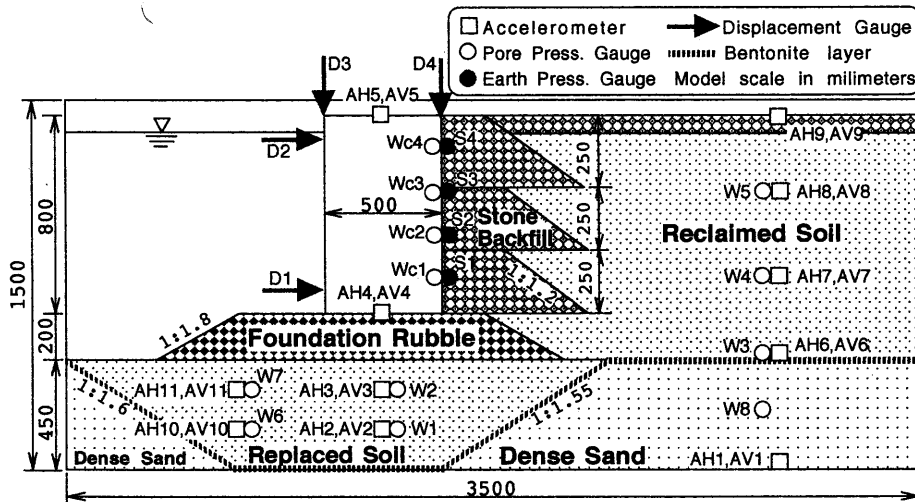

Fig. 24. Cross section of a model quay wall for shake table tests

was pluviated into the water to simulate the dumping process of sand replacement and backfill soils at the quay wall site.

The cross section of the model quay wall is shown in Fig. 24. The front end (i.e. left hand side in the figure) of the container above the model seabed level was open to the water pool whereas the back end of the container was sealed with unwoven textile reinforced with steel wire mesh to relieve adverse effects of rigid boundary conditions. Both sides of the container, however, were made of rigid steel plates to constrain the normal component of ground strain between these plates. Three model caissons were placed along the quay wall face line 1.5 m long and the caisson in the middle was used for monitoring accelerations and displacements.

The clay layer at the quay wall site was idealized in the model test by densely compacted layer of coarse grained Soma sand as shown in Fig. 24 to simulate the stable behavior of the clay layer during the earthquake. The surface of this layer was sealed with a thin bentonite layer to simulate the impermeable behavior of the clay layer during the earthquake.

The similitude in 1 g field for soil-structure-fluid system (Iai, 1989) was adopted for this study. Due to the fact that the shear modulus of sand in small strain level is proportional to the square root of the confining pressure, the scaling relation includes a scaling factor for strain as shown in Table 1. Three dimensional shaking was applied using the subsurface motion recorded at a depth of 32 m by the vertical seismic array at Port Island mentioned earlier. The peak accelerations were 544 cm/s², 461 cm/s² and 200 cm/s² in NS, EW and UD directions. The input motion was applied in accordance with the direction of the quay wall, facing west, as shown in the in-

set of Fig. 2.

As of July 31, 1995, a total of nine tests have been performed with various conditions for the model tests. After each test, the model foundation soils and backfill soils were excavated for measuring the deformation, then completely removed from the container and new virgin soils transported from Port Island were pluviated into the water to form a new model foundation and backfill for the next case. Three cases, Case-2, 6 and 7, were performed to repeatedly simulate the performance of the quay wall during the earthquake and are reported in this paper. To facilitate the comparison to those measured in the field, the test results in this paper are presented in terms of the prototype scale. The initial densities and void ratios of the model foundation and backfill are shown in Table 2. The dry densities ranging from 1.6 to 1.9 g/cm³ as shown in this table are very large probably because the Masado contains fair amount of large particles. The dry densities of the in-situ frozen samples of the Masado range from 1.7 to 2.1 g/cm³, basically consistent with those measured in the model foundation and backfill.

Residual displacements of the model caisson wall after shaking are shown in Fig. 25 together with those meas-

Table 1. Scaling factors for 1 g shake table tests

Items	Scaling factors in general (prototype/model)	Scaling factors for the present model tests (prototype/model)
x length	λ	17.0
t time	$\lambda^{0.75}$	8.4
ϵ strain	$\lambda^{0.5}$	4.1
σ stress	λ	17.0
p water pressure	λ	17.0
u displacement	$\lambda^{1.5}$	70.1
\ddot{u} acceleration	1	1.0

Table 2. Initial dry densities and void ratios of model foundation and backfill soils

Case no. of model tests	Part of the model	Dry density ρ_d (g/cm ³)	Void ratio e
Case-2	Sand replacement	1.843	0.440
	Backfill soil	1.598	0.661
Case-6	Sand replacement	1.580	0.679
	Backfill soil	1.913	0.387
Case-7	Sand replacement	1.592	0.667
	Backfill soil	1.906	0.392

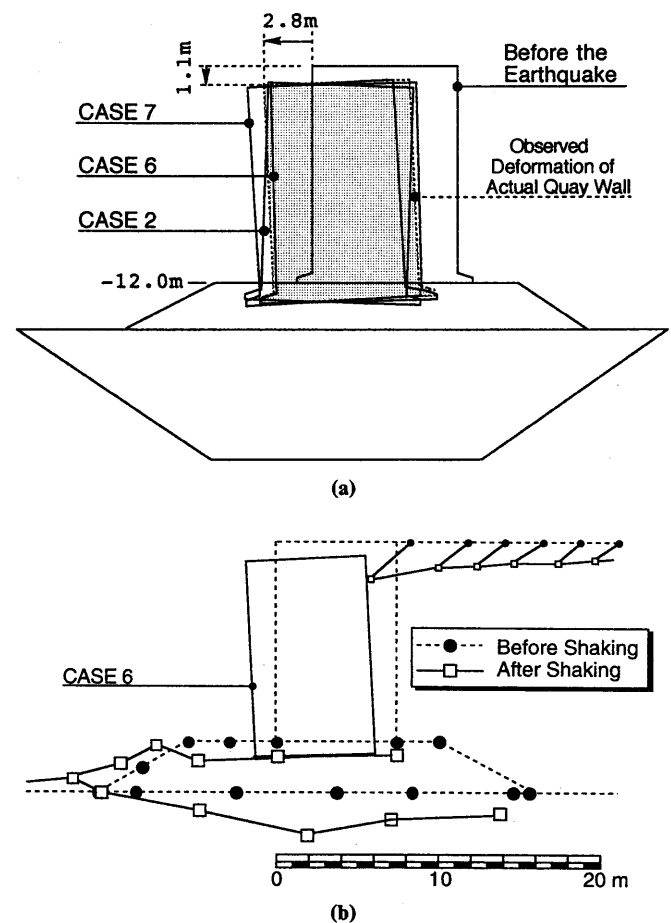

Fig. 25. Residual displacement of the model quay wall (scaled in terms of prototype)

(a) Displacements of caisson wall

(b) Deformation of foundation rubble (Case-6)

ured in the field as reproduced from Fig. 14. The model test results are basically consistent with those induced in the field during the earthquake. As shown in Fig. 25 (b), the model caisson tilted into the foundation rubble and pushed the rubble mound out. This mode of deformation of the foundation rubble is also consistent with that investigated in the field by diving mentioned earlier and shown in Fig. 23.

In order to obtain a comprehensive picture of the dynamic performance of the quay wall during the earthquake shaking, time histories of the response of the quay wall obtained by the model tests are shown in Fig. 26. Accelerations of the quay wall continued for about 20 seconds. In particular, the wave form at the ground surface is similar to that recorded at the ground surface in the Port Island shown in the upper right hand corner in the same figure. Displacements and excess pore water pressure were gradually induced with the shaking for about 10 seconds. These results indicated that displacements were induced not only by strong inertia force applied for a few seconds with one or two cycles of the strong shaking when the excess pore water pressure had not yet significantly increased in the soils but also in the later stage with a weaker motion and full excess pore water pressure increase in the soils.

In order to examine the state of the sand replacement

beneath the caisson and the backfill soils behind the caisson, excess pore water pressures are plotted in Fig. 27 together with the initial effective overburden pressures. As shown in this figure, the maximum excess pore water pressures remained more or less at the level of about half of the initial effective overburden pressures both in the sand replacement and the backfill soils. The in-situ observation of the quay walls suggested that there were generally a lack of sand boils in the backfill soils in the vicinity of the caisson walls whereas in the landfill soils further inland there was extensive evidence of liquefaction. The rather low excess pore water pressures in the backfill soils of the model tests might be exaggerated partly due to the effect of the boundary condition at the land side but they were basically consistent with the observations of lack of sand boils in the vicinity of the caisson walls.

The low excess pore water pressures in the sand replacement might be caused by another mechanism; i.e. the existence of static deviator stress due to the dead weight of the caisson.

The important findings from the shake table tests on the performance of the caisson type quay walls can be summarized as follows. The excess pore water pressure ratios in the sand replacement increased only about 50% during the earthquake but this increase certainly affected the quay wall deformation; the main cause of the defor-

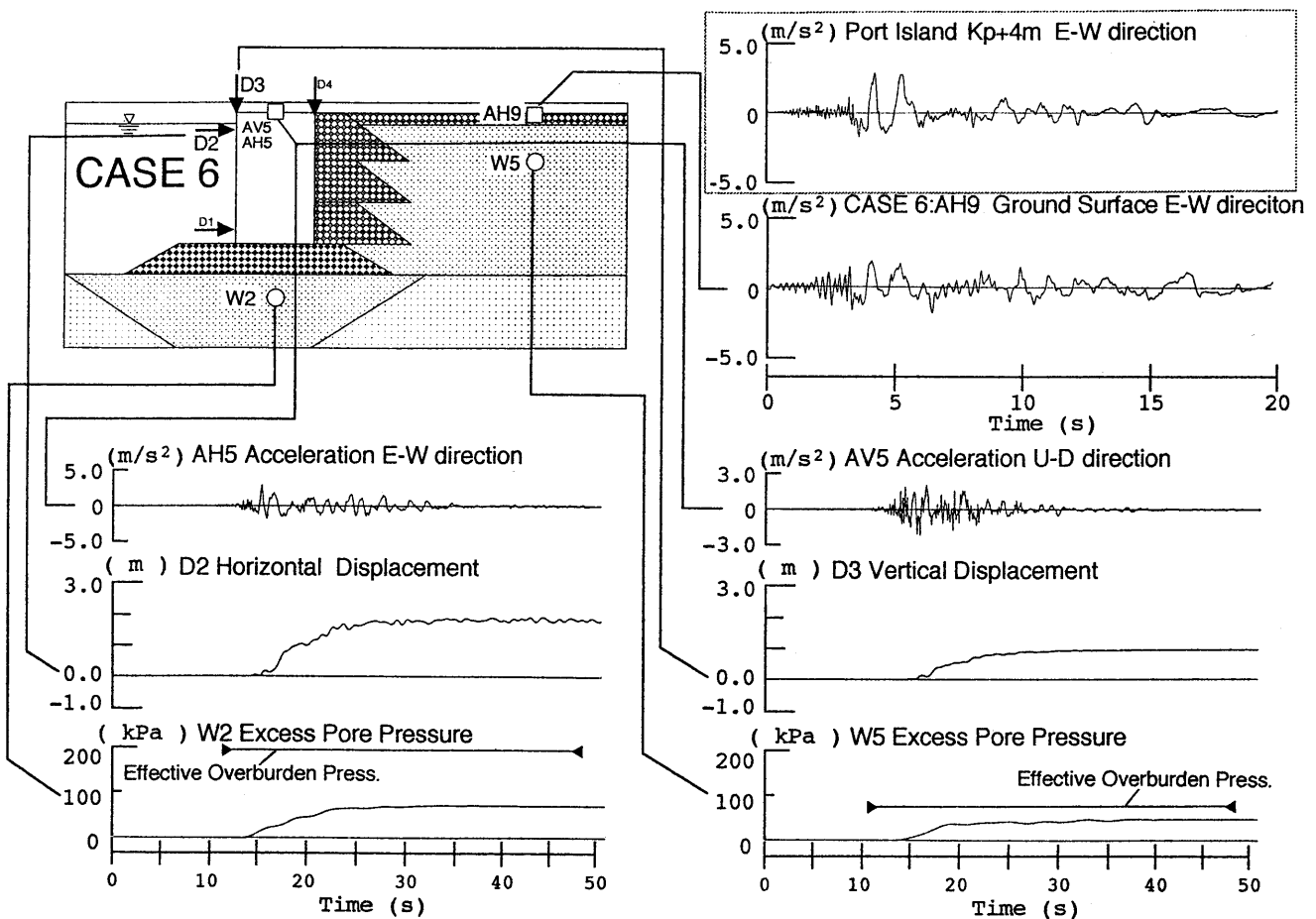

Fig. 26. Time histories of model quay wall response (scaled in terms of prototype) (Case-6) and the recorded time history of acceleration at the ground surface for Port Island

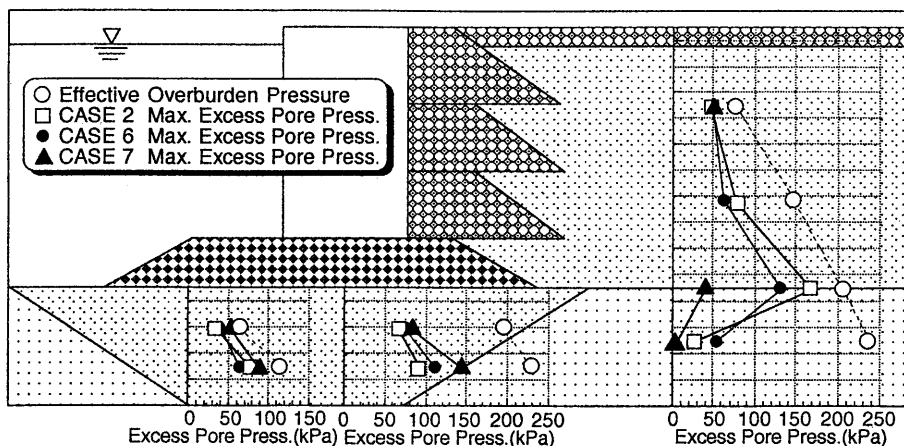

Fig. 27. Distribution of maximum excess pore water pressures obtained from shake table tests (scaled in terms of prototype)

mation was not the sliding along the bottom of the caisson but a significant deformation of the foundation rubble mound and the foundation soils beneath it.

The results reported here are preliminary and a further study is currently under way. A full report on the shake table tests will be prepared in the near future.

SUMMARY AND CONCLUSIONS

The 1995 Hyogoken-Nambu earthquake was a very good example to evaluate earthquake resistance of caisson type quay walls. These caisson walls in Kobe Port were shaken with peak ground accelerations of 0.54 g and 0.45 g in the horizontal and vertical directions. A summary of the performance of the caisson walls and the conclusions which can be drawn from this study are as follows.

(1) In-situ freezing sampling of Masado (i.e. decomposed granite) and cyclic triaxial tests indicated that, although the Masado contains large particles, the correlation of cyclic stress ratios with SPT *N*-values of Masado is basically consistent with those of clean and silty sands obtained from past studies.

(2) Most of the caisson type quay walls exhibited seaward displacements of about 5 m maximum and 3 m average. They deformed quite uniformly maintaining almost straight face lines of the walls. No collapse or overturning was involved.

(3) The caisson type high seismic resistant quay walls, which were specifically designed for unloading emergency supplies to the areas devastated by the earthquake, performed very well resisting the strong earthquake motion.

(4) The displacements of the caisson walls revealed a close correlation with the thickness of the sand replacement beneath the caisson walls. In particular, the caisson walls constructed on the foundation improved by sand compaction piles (SCP) showed much smaller displacements than those constructed on the sand replacement foundation without compaction.

(5) The shake table tests indicated that the displace-

ments of the caisson were not suddenly induced during the first few cycles of strong shaking but rather were gradually induced with increase of excess pore water pressures in the backfill and the foundation soils beneath the caisson walls.

(6) Both the shake table tests and the in-situ investigation by diving suggested that the mechanism of the deformation of the caisson is not the sliding of the caisson as often assumed in the conventional simplified analysis but an overall deformation of the foundation soils beneath the caisson.

(7) The shake table tests indicated that the excess pore water pressures in the sand replacement beneath the caisson did not reach 50% of the initial confining pressures. This might be due to the effect of static deviator stress in the sand replacement due to the dead weight of the caisson.

A more detailed and extensive report on the performance of the port facilities in the 1995 Hyogoken-Nambu earthquake will be published in December 1995 by the Port and Harbour Research Institute. Another detailed report of the restoration design will follow this publication by the Third District Port Construction Bureau. The final comprehensive report will be compiled and published in early 1996 jointly by the Ports and Harbours Bureau, the Port and Harbour Research Institute, and the Third District Port Construction Bureau, of Ministry of Transport, Japan. All the reports will be published in Japanese with an English abstract.

ACKNOWLEDGMENTS

This paper is based on extensive efforts of a large number of engineers and researchers involved with port construction in Japan. In particular, the authors wish to express their sincere gratitude to Kobe Port Terminal Co. for part of the in-situ investigations, and to Kobe City for kindly permitting the authors to use the vertical seismic array records at Port Island.

The shake table tests were conducted as a joint study between the Port and Harbour Research Institute

(PHRI) and the Penta-Ocean Construction Institute of Technology (POINT). Special thanks are due to Dr. Masaaki Mito, POINT, for his significant contribution in the shake table tests.

REFERENCES

- 1) Fudo Construction Co. (1995): "Preliminary reconnaissance report on 1995 Hyogo-ken Nanbu earthquake," A Booklet, pp. 1-46 (in Japanese).
- 2) Iai, S. (1989): "Similitude for shaking table tests on soil-structure-fluid model in 1 g gravitational field," *Soils and Foundations*, Vol. 29, No. 1, pp. 105-118.
- 3) Iai, S., Tsuchida, H. and Koizumi, K. (1989): "A liquefaction criterion based on field performances around seismograph stations," *Soils and Foundations*, Vol. 29, No. 2, pp. 52-68.
- 4) Japanese Society of Soil Mechanics and Foundation Engineering (1982): "Geotechnical Investigation Methods, Second Edition," p. 122 (in Japanese).
- 5) Ministry of Transport (ed.) (1991): "Technical Standards for Port and Harbour Facilities in Japan, New Edition," Overseas Coastal Area Development Institute of Japan, pp. 1-438.
- 6) Seed, H. B., Tokimatsu, K., Harder, L. F. and Chung, R. M. (1985): "Influence of SPT procedures in soil liquefaction resistance evaluations," *Journal of Geotechnical Engineering Division, ASCE*, Vol. 111, No. 12, pp. 1425-1445.
- 7) Tsuchida, H. (1970): "Evaluation of liquefaction potential of sandy deposits and measures against liquefaction induced damage," *Proceedings of the Annual Seminar of the Port and Harbour Research Institute*, pp. (3-1)-(3-33) (in Japanese).
- 8) Yoshimi, Y. (1993): "Relation among liquefaction resistance, SPT *N*-value and relative density for undisturbed samples of clean sands," 28th Japan National Conference on Soil Mechanics and Foundation Engineering, pp. 977-978 (in Japanese).